

POWERS STEEL LINTEL NOTES

1. PRODUCT NAME POWERS STEEL LINTELS (PATENT NO. 4757656; SBCCI PST & ESI # 93-132)
 PREFORMED POWERS STEEL LINTEL SHALL BE GALVANIZED COIL STEEL AS MANUFACTURED BY POWERS STEEL AND WIRE PRODUCTS, INC. STEEL GRADE SHALL BE ASTM A1011/A1011M-07 $F_y=40$ ksi. MINIMUM. STEEL SHALL BE CLEAN AND FREE OF ANY MATERIAL THAT MIGHT INHIBIT BOND.
2. SHORE LINTELS AS REQUIRED TO COMPENSATE FOR DEAD LOAD DEFLECTION ON NON-CURED MASONRY.
3. LINTELS TO BE USED WITH BRICK OR CONCRETE MASONRY UNITS HAVING A MINIMUM f'_m AS SHOWN.
4. STEEL SURFACES IN CONTACT WITH GROUT AND/OR MORTAR SHALL BE UNPAINTED AND FREE OF MATERIAL THAT MIGHT INHIBIT BOND.
5. BEARING EACH END SHALL BE 4" PLUS OR MINUS 1". BEARING SHALL BE ON A MINIMUM 8" DEEP GROUTED CELL.
6. f'_m : 1500 psi. MASONRY UNITS SHALL CONFORM TO ASTM C90, GRADE N. USE OPEN END MASONRY UNITS AT LINTELS TO ALLOW SOLID GROUTING.
7. GROUT: 2,000 psi SLUMP RANGE: 8" TO 11". GROUT SHALL COMPLY WITH ASTM C476-83 AND BE EITHER COARSE OR FINE GROUT. GROUT SHALL BE CONSOLIDATED BY MECHANICAL VIBRATION DURING PLACING BEFORE LOSS OF PLASTICITY IN A MANNER TO FILL THE GROUT SPACE. GROUT POURS GREATER THAN 12 INCHES SHALL BE RECONSOLIDATED BY MECHANICAL VIBRATION TO MINIMIZE VOIDS DUE TO WATER LOSS. GROUT POURS 12 INCHES OR LESS IN HEIGHT SHALL BE MECHANICALLY VIBRATED, OR PUDDLED.
8. MORTAR: TYPE "S" OR TYPE "M" 1800 psi.
9. TOP REINFORCING, OR TOP OF WALL REINFORCING, IS REQUIRED BY CODES TO PROVIDE A CONTINUOUS TIE AROUND A STRUCTURE AND TO PROVIDE FOR UPLIFT RESISTANCE AT LINTELS. TOP REINFORCING IS NOT REQUIRED AND IS NOT PART OF THE POWERS STEEL LINTELS. (EXCEPT THAT A REINFORCING BAR IS REQUIRED AT THE TOP OF THE STEEL STIRRUPS) SIZING OF THE TOP REINFORCING IS THE RESPONSIBILITY OF THE BUILDING ARCHITECT OR ENGINEER.
10. ATTACHMENTS TO TOP OF WALL PER ARCHITECTURAL AND/OR ENGINEERING DRAWINGS.
11. MASONRY WALL MAY OCCUR ABOVE COMPOSITE LINTEL HEIGHT.
12. #5 REINFORCING BAR (GRADE 60) TO BEAR ON BOTTOM OF STEEL LINTEL AS SHOWN AND TO BE THE SAME LENGTH AS LINTEL. NOTE: #5 ONLY REQUIRED AT LINTELS WHERE SPECIFICALLY NOTED.
13. INSTALLATION: POWERS LINTELS ARE TO BE INSTALLED IN ACCORDANCE WITH STANDARD CONSTRUCTION PRACTICES, SET TO PROPER LINE AND LEVEL, PLUMB AND TRUE, AND IN CORRECT RELATION TO OTHER WORK.

14. STRUCTURAL ENGINEER FOR THESE LINTELS IS:

CARUSO TURLEY SCOTT INC.
 1215 W. Rio Salado Parkway Suite #200
 Tempe, Arizona 85281
 Direct Phone No. (480) 774-1776
 Fax (480) 774-1701
 Paul G. Scott P.E.
 Pscott@ctsaz.com

IF AN INSPECTOR, CONTRACTOR, SUBCONTRACTOR, OR PLANS EXAMINER HAS ANY TECHNICAL QUESTIONS PLEASE CALL CARUSO, TURLEY SCOTT INC.

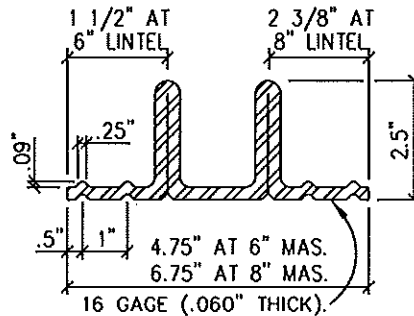

15. LINES SHOWN INDICATE THE #4 REINFORCING BAR CODE REQUIRED MINIMUM REINFORCING AROUND WALL OPENINGS. ENGINEER, ARCHITECT, OR DESIGNER TO VERIFY ACTUAL REINFORCING REQUIRED.
16. SPECIAL INSPECTION IS REQUIRED FOR GROUT PLACEMENT OF THESE LINTELS. IF NO SPECIAL INSPECTION IS PROVIDED THE ALLOWABLE LOADS SHALL BE ONE HALF OF THOSE SHOWN IN THE TABLE.



STEEL LINTELS

NO SCALE

FILE: Powers Lintels CTS
 PAGE: PDS1 3-27-14

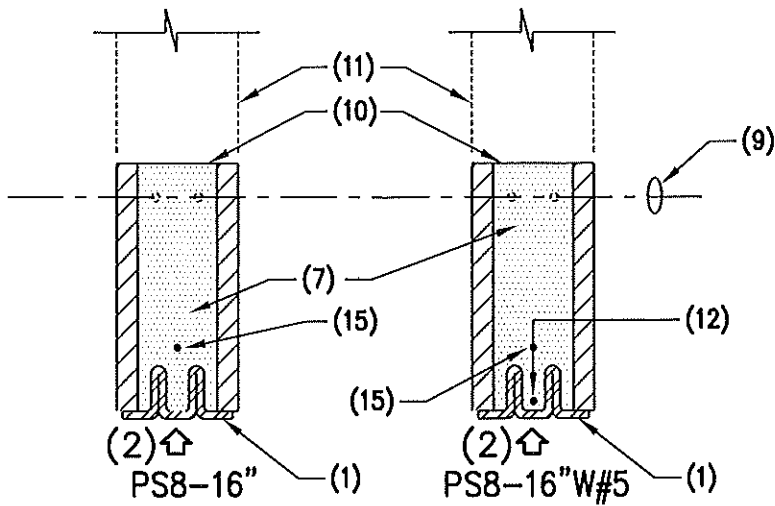

LINTEL EXAMPLE SECTIONS

NOTE: LINTEL HEIGHTS VARY - SEE PLANS AND SCHEDULES.

NOTE:

↑ INDICATES SHORING OF LINTEL AND MASONRY FOR DEAD LOAD DEFLECTION OF NON-CURED MASONRY.

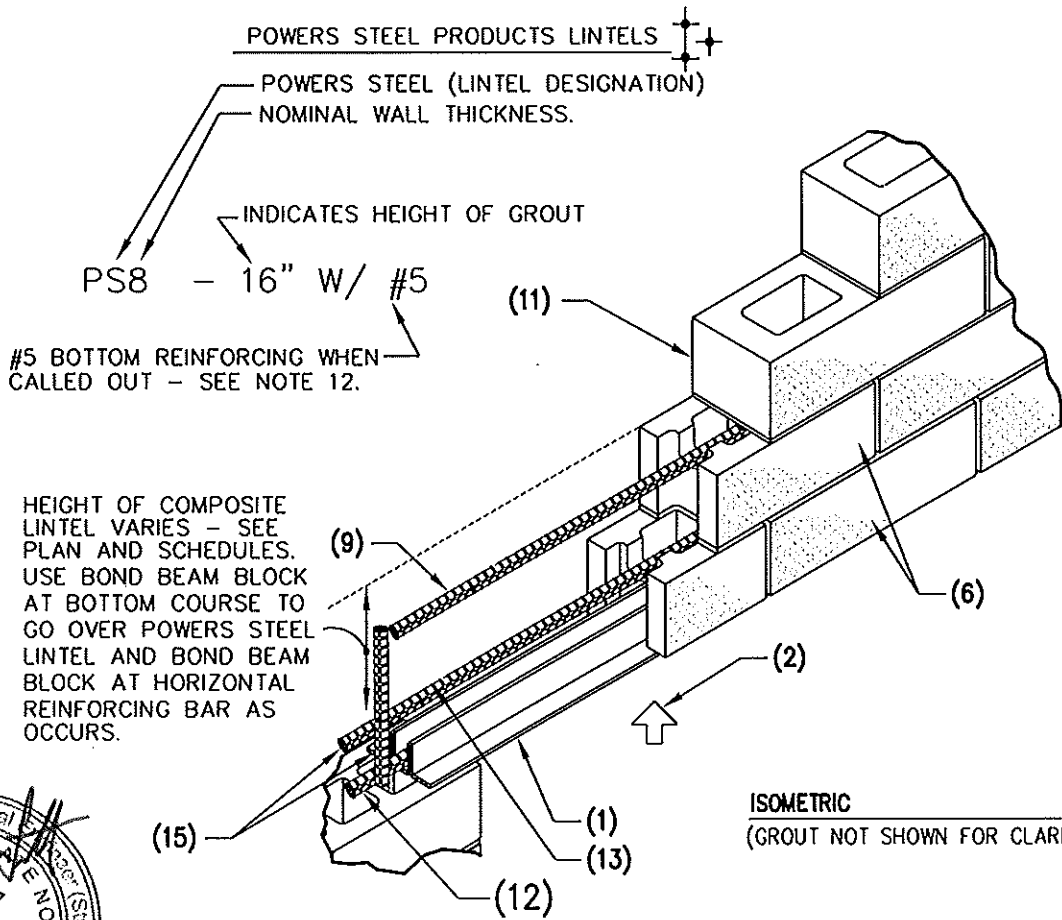

POWERS STEEL PRODUCTS LINTELS

POWERS STEEL (LINTEL DESIGNATION)
NOMINAL WALL THICKNESS.

INDICATES HEIGHT OF GROUT

PS8 - 16" W/ #5

#5 BOTTOM REINFORCING WHEN CALLED OUT - SEE NOTE 12.

HEIGHT OF COMPOSITE LINTEL VARIES - SEE PLAN AND SCHEDULES. USE BOND BEAM BLOCK AT BOTTOM COURSE TO GO OVER POWERS STEEL LINTEL AND BOND BEAM BLOCK AT HORIZONTAL REINFORCING BAR AS OCCURS.

ISOMETRIC

(GROUT NOT SHOWN FOR CLARITY)

POWERS STEEL LINTELS DETAILS

FILE: Powers Lintels CTS
PAGE: PDS2 3-27-14



POWERS STEEL PRODUCTS LINTELS† PS6 LINTELS

LINTEL LOAD TABLE (IN POUNDS PER LINEAL FOOT)

DEAD LOAD PLUS LIVE LOAD

SPAN	PS6-8"	PS6-12" W/#5	PS6-12" W/#5	PS6-16" W/#5	PS6-16" W/#5	PS6-20" W/#5	PS6-20" W/#5	PS6-24" W/#5	PS6-24" W/#5	PS6-32" W/#5	PS6-32" W/#5	PS6-40" W/#5	PS6-40" W/#5	PS6-48" W/#5	PS6-48" W/#5	SPAN
2'-0"	1242	1990	1948	2756	2699	3534	3463	4320	4237	5910	5804	7518	7392	9139	8993	2'-0"
2'-8"	930	1491	1459	2064	2022	2647	2594	3236	3173	4427	4348	5631	5537	6845	6736	2'-8"
3'-4"	746	1195	1170	1655	1621	2122	2080	2594	2544	3550	3486	4515	4439	5489	5401	3'-4"
4'-0"	621	995	974	1378	1350	1767	1732	2160	2118	2955	2902	3759	3696	4569	4497	4'-0"
4'-8"	532	852	834	1180	1156	1513	1483	1850	1814	2531	2486	3220	3166	3914	3851	4'-8"
5'-4"	466	747	731	1034	1013	1326	1299	1621	1590	2218	2178	2821	2774	3429	3374	5'-4"
6'-0"	414	663	649	919	900	1178	1154	1440	1412	1970	1935	2506	2464	3046	2998	6'-0"
6'-8"	372	597	584	826	809	1060	1038	1295	1270	1772	1740	2254	2216	2740	2697	6'-8"
7'-4"	339	543	531	752	736	964	945	1179	1156	1613	1584	2051	2017	2493	2454	7'-4"
8'-0"	310	498	487	689	675	883	866	1080	1059	1478	1451	1880	1848	2285	2248	8'-0"
8'-8"	286	459	449	636	623	815	799	996	977	1363	1339	1734	1705	2108	2075	8'-8"
9'-4"	266	427	417	591	579	757	742	926	908	1267	1244	1612	1584	1959	1928	9'-4"
10'-0"	245	398	390	551	540	707	693	864	847	1182	1161	1504	1478	1828	1799	10'-0"
10'-8"	215	373	365	517	506	662	649	810	794	1108	1088	1409	1385	1713	1686	10'-8"
11'-4"		351	344	486	476	624	611	762	748	1043	1025	1327	1305	1613	1587	11'-4"
12'-0"		332	325	459	450	589	577	720	706	985	967	1253	1232	1523	1499	12'-0"
12'-8"		314	307	435	426	558	547	682	669	933	916	1187	1167	1443	1420	12'-8"
13'-4"		299	292	414	405	530	520	648	636	887	871	1128	1109	1371	1349	13'-4"
14'-0"		275	278	394	386	505	495	617	605	744	729	1074	1056	1306	1285	14'-0"
14'-8"		250	266	376	368	482	472	589	578	806	791	1025	1008	1246	1226	14'-8"
15'-4"		229	245	360	352	461	452	564	553	771	757	981	964	1192	1173	15'-4"
16'-0"		210	225	345	337	442	433	540	530	739	726	940	924	1142	1124	16'-0"
16'-8"			207	330	324	424	415	518	508	709	696	902	887	1096	1079	16'-8"
17'-4"				305	311	408	400	498	489	682	670	868	853	1055	1038	17'-4"
18'-0"				283	300	393	385	480	471	657	645	835	821	1015	999	18'-0"
18'-8"				263	284	379	371	463	454	633	622	805	792	979	963	18'-8"
19'-4"				246	265	366	358	447	438	611	601	778	765	946	930	19'-4"
20'-0"				229	247	343	346	432	424	591	580	752	739	914	899	20'-0"
20'-8"				215	232	321	335	418	410	572	562	727	715	884	870	20'-8"
21'-4"				202	218	302	325	405	397	554	544	705	693	857	843	21'-4"
22'-0"					205	284	308	392	385	537	528	683	672	831	818	22'-0"
22'-8"						267	290	369	374	521	512	663	652	806	793	22'-8"
23'-4"						252	274	348	363	507	498	644	634	783	771	23'-4"
24'-0"						238	259	329	353	493	484	627	616	762	749	24'-0"
24'-8"						226	245	312	340	479	471	609	599	741	729	24'-8"
25'-4"						214	232	296	322	467	458	594	584	722	710	25'-4"
26'-0"						203	220	280	306	455	446	578	569	703	692	26'-0"
26'-8"							209	267	291	440	435	564	554	685	674	26'-8"
27'-4"								254	277	419	425	541	541	669	658	27'-4"
28'-0"								242	264	399	415	537	528	653	642	28'-0"
28'-8"								231	252	380	405	524	516	637	627	28'-8"
29'-4"								220	240	364	396	513	504	623	613	29'-4"
30'-0"								211	230	347	382	501	493	609	600	30'-0"

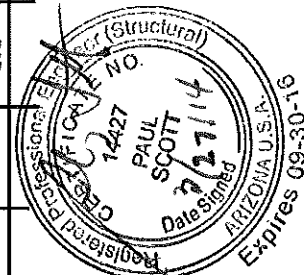

POWERS STEEL PRODUCTS LINTELS PS8 LINTELS

FILE: Powers Lintels CTS
PAGE: POSS 3-27-14

SPECIAL INSPECTION IS REQUIRED FOR GROUT PLACEMENT OF THESE LINTELS. IF NO SPECIAL INSPECTION IS PROVIDED THE ALLOWABLE LOADS SHALL BE ONE HALF OF THOSE SHOWN IN THE TABLE.

LINTEL LOAD TABLE (IN POUNDS PER LINEAL FOOT)

DEAD LOAD PLUS LIVE LOAD

SPAN	PS8-8"	PS8-12"	PS8-12"	PS8-16"	PS8-16"	PS8-20"	PS8-20"	PS8-24"	PS8-24"	PS8-32"	PS8-32"	PS8-40"	PS8-40"	PS8-48"	PS8-48"	SPAN
	W/#S	W/#S	W/#S	W/#S	W/#S	W/#S	W/#S	W/#S	W/#S	W/#S	W/#S	W/#S	W/#S	W/#S	W/#S	
2'-0"	1705	2730	2679	3779	3711	4843	4760	5918	5820	8090	7967	10284	10138	12494	12327	2'-0"
2'-8"	1277	2045	2007	2831	2780	3628	3565	4433	4360	6060	5967	7703	7594	9359	9233	2'-8"
3'-4"	1024	1640	1609	2270	2229	2909	2859	3455	3495	4859	4785	6177	6089	7504	7403	3'-4"
4'-0"	852	1365	1340	1856	1856	2422	2380	2959	2910	4045	3983	5142	5069	6247	6163	4'-0"
4'-8"	730	1169	1147	1589	1589	2074	2038	2534	2493	3464	3412	4404	4342	5351	5279	4'-8"
5'-4"	640	1024	1005	1418	1392	1817	1786	2220	2184	3035	2989	3859	3804	4688	4625	5'-4"
6'-0"	568	910	893	1237	1237	1614	1587	1973	1940	2697	2656	3428	3379	4165	4109	6'-0"
6'-8"	511	819	803	1133	1113	1452	1427	1774	1744	2426	2389	3084	3040	3746	3696	6'-8"
7'-4"	465	745	731	1031	1013	1321	1299	1615	1588	2207	2174	2806	2766	3409	3363	7'-4"
8'-0"	426	683	670	945	928	1211	1190	1479	1455	2022	1992	2571	2534	3124	3082	8'-0"
8'-8"	393	630	618	872	856	1117	1098	1365	1343	1866	1838	2372	2339	2882	2843	8'-8"
9'-4"	365	585	574	810	795	1038	1020	1268	1248	1734	1708	2205	2173	2678	2642	9'-4"
10'-0"	321	546	536	756	742	969	952	1184	1164	1618	1593	2057	2028	2499	2465	10'-0"
10'-8"	282	512	502	708	696	908	892	1109	1091	1516	1493	1928	1900	2342	2310	10'-8"
11'-4"	250	482	473	667	655	855	840	1045	1027	1428	1406	1815	1789	2205	2176	11'-4"
12'-0"	223	455	447	630	619	807	793	986	970	1348	1328	1714	1690	2082	2054	12'-0"
12'-8"	200	431	423	597	586	764	751	934	919	1277	1258	1623	1600	1972	1946	12'-8"
13'-4"		393	402	567	557	727	714	888	873	1214	1195	1543	1521	1875	1849	13'-4"
14'-0"		357	381	540	530	692	680	845	831	1156	1138	1469	1448	1785	1761	14'-0"
14'-8"		325	347	515	506	660	649	807	793	1103	1086	1402	1382	1703	1681	14'-8"
15'-4"		297	317	493	484	632	621	772	759	1055	1039	1342	1323	1630	1608	15'-4"
16'-0"		273	291	463	464	605	595	740	728	1011	996	1286	1267	1562	1541	16'-0"
16'-8"		252	268	427	445	581	571	710	698	971	956	1234	1216	1499	1479	16'-8"
17'-4"		233	248	395	425	559	549	683	672	934	919	1187	1170	1442	1423	17'-4"
18'-0"		216	230	366	394	538	529	658	647	899	885	1143	1126	1388	1370	18'-0"
18'-8"		201	214	340	366	507	510	634	623	867	853	1102	1086	1338	1320	18'-8"
19'-4"		200	200	317	341	473	492	612	602	837	824	1064	1049	1293	1275	19'-4"
20'-0"			297	319	442	476	476	592	582	809	797	1028	1014	1249	1233	20'-0"
20'-8"			278	298	414	447	447	570	563	783	771	995	981	1209	1193	20'-8"
21'-4"			261	280	389	420	420	536	546	759	747	964	951	1171	1156	21'-4"
22'-0"			245	263	365	395	395	503	529	735	724	935	922	1136	1121	22'-0"
22'-8"			231	248	344	372	372	474	513	714	703	907	894	1102	1087	22'-8"
23'-4"			218	234	325	351	351	448	486	693	683	882	869	1071	1057	23'-4"
24'-0"			206	221	307	332	332	423	459	674	664	857	845	1041	1027	24'-0"
24'-8"				210	291	314	314	400	435	656	646	834	822	1013	999	24'-8"
25'-4"					276	298	298	380	412	639	629	812	800	986	973	25'-4"
26'-0"					262	283	283	360	391	622	613	791	780	961	948	26'-0"
26'-8"					249	269	269	343	372	563	557	771	760	937	924	26'-8"
27'-4"					237	256	256	326	354	536	533	739	742	897	890	27'-4"
28'-0"					226	244	244	311	337	511	508	704	724	855	855	28'-0"
28'-8"					215	233	233	296	322	487	487	671	707	815	860	28'-8"
29'-4"					206	222	222	283	307	465	465	641	691	779	841	29'-4"
30'-0"						212	212	271	294	445	445	613	676	745	822	30'-0"

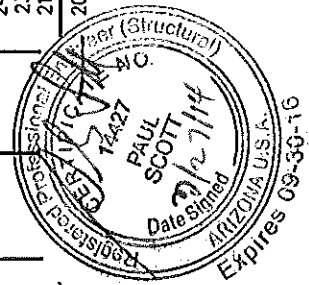

Expires 09-30-16

6PS I-BEAM LINTELS POWERS STEEL PRODUCTS LINTELS †‡

NOTES:

1. MINIMUM BEARING SHALL BE 6" ON SOLID GROUTED MASONRY.
2. STEEL GRADE IS ASTM A570, GRADE C, Fy = 36.0 KSI.
3. NOT TO BE USED WITH GYPSUM UNBURNED CLAY, BURNT ADOBE AND CAVITY WALL MASONRY.
4. FOR SPANS LARGER THAN 5'-0", LINTELS MUST BE SHORED AT MIDSPAN UNTIL MASONRY HAS CURED.
5. REBAR GRADE IS ASTM A615 - GRADE 60.
6. CITY OF PHOENIX STANDARD PLAN LPST 96-0017
7. LINES SHOWN INDICATE THE #4 REINFORCING BAR CODE REQUIRED MINIMUM REINFORCING AROUND WALL OPENINGS. ENGINEER, ARCHITECT, OR DESIGNER TO VERIFY ACTUAL REINFORCING REQUIRED

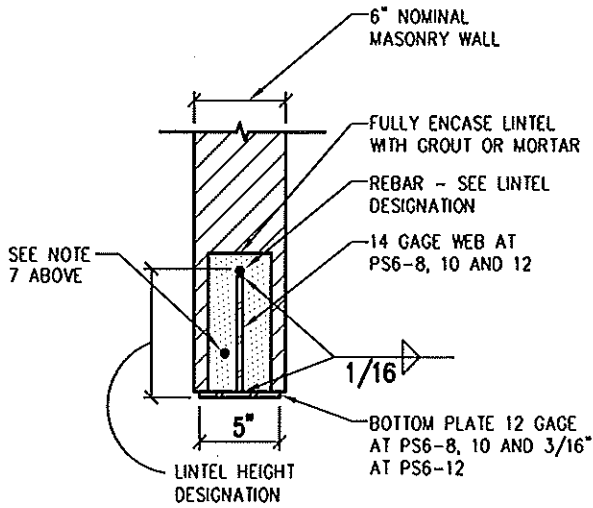
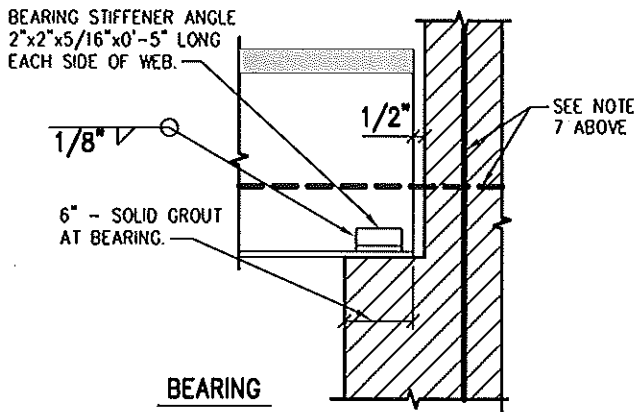
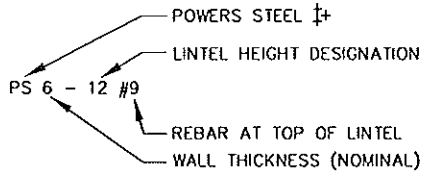

8" (8)
10" (10)
12" (12)

LINTEL	PS6-8#7	PS6-10#8	PS6-12#9
SPAN	ALLOWABLE LOAD #/FT	ALLOWABLE LOAD #/FT	ALLOWABLE LOAD #/FT
3'-4"	3514	3514	3514
4'-0"	2925	2925	2925
4'-8"	2507	2507	2507
5'-4"	2195	2195	2195
6'-0"	1793	1950	1950
6'-8"	1452	1755	1755
7'-4"	1200	1596	1596
8'-0"	1005	1430	1463
8'-8"	855	1218	1350
9'-4"	740	1051	1254
10'-0"	640	915	1170
10'-8"	565	800	1097
11'-4"	500	710	1033
12'-0"	445	635	975
12'-8"	400	570	924
13'-4"	360	515	878
14'-0"	330	465	836
14'-8"	295	425	773
15'-4"	275	390	708
16'-0"	250	355	650
16'-8"	230	330	599
17'-4"	215	305	554
18'-0"	200	280	513
18'-8"	180	260	477
19'-4"	---	245	445
20'-0"	---	230	415
20'-8"	---	215	385
21'-4"	---	200	360
22'-0"	---	190	340
22'-8"	---	175	325
23'-4"	---	165	305
24'-0"	---	155	285

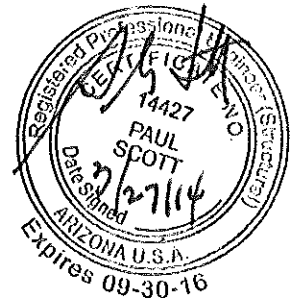

CARUSO ■ TURLEY ■ SCOTT ■ INC. CONSULTING STRUCTURAL ENGINEERS

130 SOUTH PRIEST DRIVE

TEMPE, ARIZONA 85281 (480) 774-1776

FAX (480) 774-1701

TITLE POWERS STEEL 6PS I-BEAM LINTELS	JOB NUMBER 96-114	DRAWN TMH	SHEET 1 OF
	DATE 3-27-14	ENGR PGS	

8PS I-BEAM LINTELS POWERS STEEL PRODUCTS LINTELS †

NOTES:

1. MINIMUM BEARING SHALL BE 6" ON SOLID GROUTED MASONRY.
2. STEEL GRADE IS ASTM A570, GRADE C, $F_y = 36.0$ KSI.
3. NOT TO BE USED WITH GYPSUM UNBURNED CLAY, BURNT ADOBE AND CAVITY WALL MASONRY.
4. FOR SPANS LARGER THAN 5'-0", LINTELS MUST BE SHORED AT MIDSPAN UNTIL MASONRY HAS CURED.
5. REBAR GRADE IS ASTM A615 - GRADE 60.
6. CITY OF PHOENIX STANDARD PLAN LPST 96-0017
7. LINES SHOWN INDICATE THE #4 REINFORCING BAR CODE REQUIRED MINIMUM REINFORCING AROUND WALL OPENINGS. ENGINEER, ARCHITECT, OR DESIGNER TO VERIFY ACTUAL REINFORCING REQUIRED

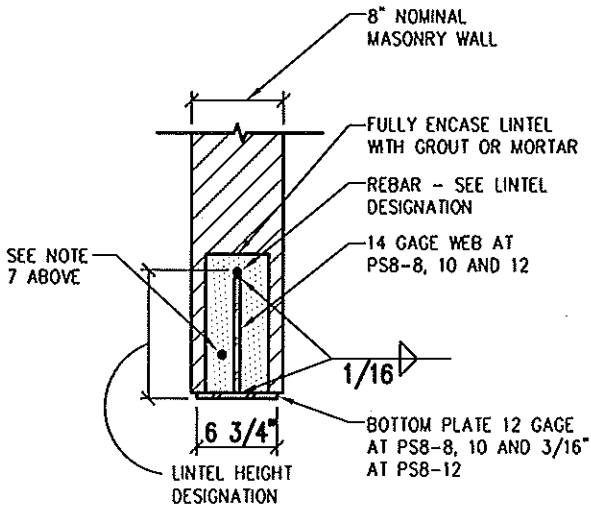
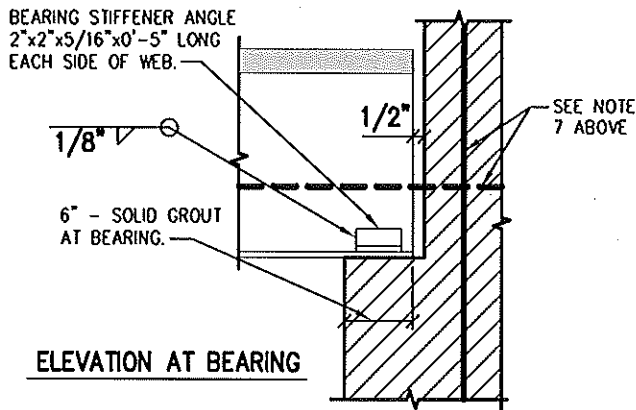
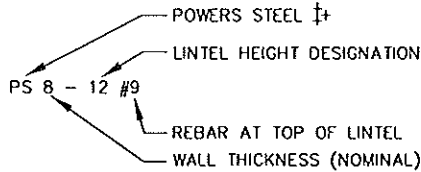

SECTION
8" (8)
10" (10)
12" (12)

LINTEL	PS8-8#7	PS8-10#8	PS8-12#9
SPAN	ALLOWABLE LOAD #/FT	ALLOWABLE LOAD #/FT	ALLOWABLE LOAD #/FT
3'-4"	3851	3851	3851
4'-0"	3206	3206	3206
4'-8"	2748	2748	2748
5'-4"	2362	2406	2406
6'-0"	1865	2137	2137
6'-8"	1505	1923	1923
7'-4"	1250	1749	1749
8'-0"	1050	1603	1603
8'-8"	890	1449	1480
9'-4"	770	1250	1374
10'-0"	670	1090	1282
10'-8"	590	955	1202
11'-4"	520	845	1132
12'-0"	465	755	1069
12'-8"	415	675	1012
13'-4"	380	610	962
14'-0"	340	555	875
14'-8"	315	505	800
15'-4"	285	460	730
16'-0"	265	425	670
16'-8"	240	390	620
17'-4"	220	360	570
18'-0"	200	335	530
18'-8"	190	310	490
19'-4"	175	290	460
20'-0"	165	270	430
20'-8"	---	255	400
21'-4"	---	240	375
22'-0"	---	225	355
22'-8"	---	210	335
23'-4"	---	200	315
24'-0"	---	190	300



CARUSO ■ TURLEY ■ SCOTT ■ INC. CONSULTING STRUCTURAL ENGINEERS

130 SOUTH PRIEST DRIVE

TEMPE, ARIZONA 85281 (480) 774-1776

FAX (480) 774-1701

TITLE POWERS STEEL 8PS I-BEAM LINTELS	JOB NUMBER 96-114	DRAWN TMH	SHEET 2 OF
	DATE 3-27-14	ENGR PCS	